

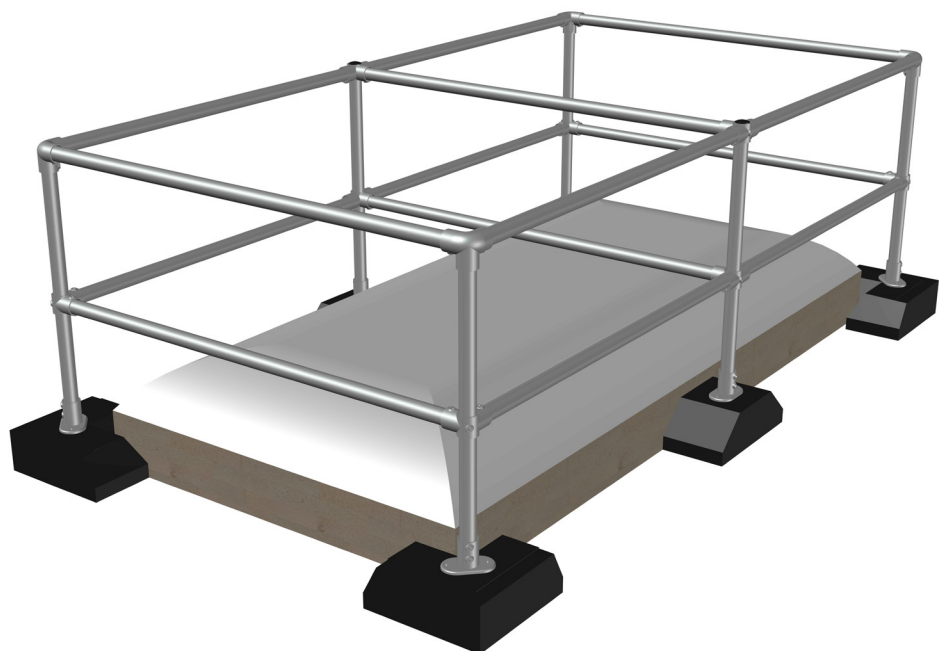

Freestanding Rooflight Protection System

Operation & Maintenance Manual

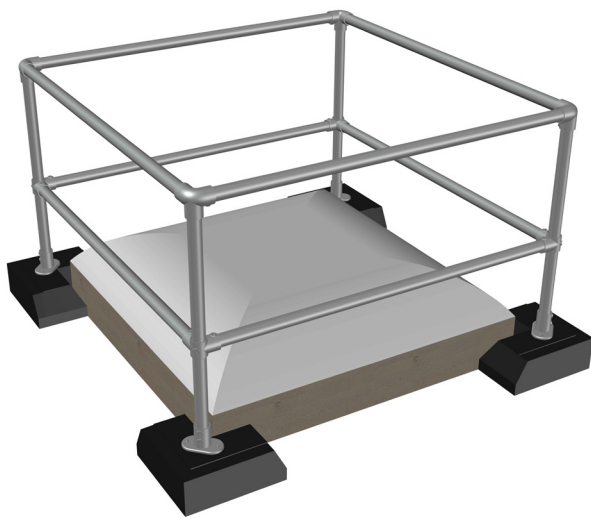

Specification

Free Standing Rooflight Protection - System Specification



General Description

Our freestanding rooflight protection system is a weighted guardrail system that does not require any mechanical fixing into the roof surface. This system has been designed and manufactured to fully comply with current H.S.E regulations.

Material

The system is assembled using 1.5mm x 48.3mm external diameter galvanised steel tube, and galvanised malleable cast iron fittings. The weighted feet are manufactured from 100% recycled PVC compound with the fixing screws manufactured from zinc-coated steel.

Safety Standards

Our freestanding system is designed in accordance with the following safety standards:

- HSG-33 Health and safety in roof work.
- HSE INDG 284 "Working on roofs".
- EN ISO 14122 Part 3.
- EN 13374-2013 Class A.
- BS 6399: Part 2 1995 Wind Code.

Contact

Free Standing Rooflight Protection - Manufacturers Details

If you have any queries in regards to the rooflight protection system or the content in this O&M Manual please do not hesitate to contact Roofco Ltd via post, telephone, fax or email using the information below.



Address:
Roofco Ltd
Unit One,
Ross Street,
Darnall,
Sheffield
S9 4PU

Telephone:
+44 (0) 114 243 6001

Fax:
+44 (0) 114 243 6060

Email:
sales@roofco.co.uk

Components

Free Standing Rooflight Protection - System Components

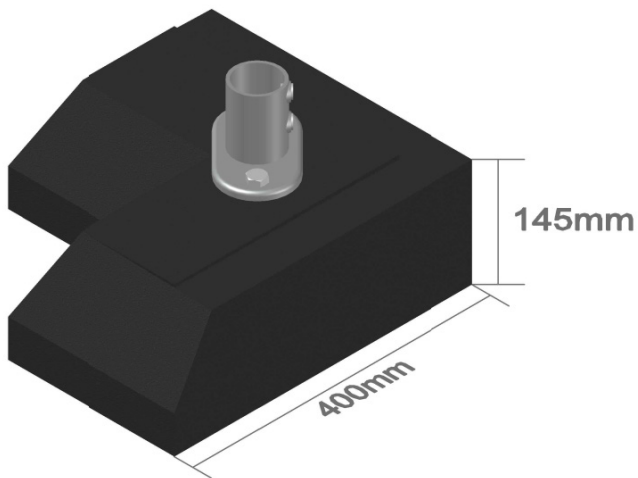

Corner Foot

The corner foot sits on the roof covering, positioned adjacent to the corner of the rooflight. A railing base flange is mechanically attached to this using zinc coated fixings, providing a base for upright stanchions.

Weighing 18 kg it provides a stable base to the system.

Materials

Manufactured from recycled PVC compound

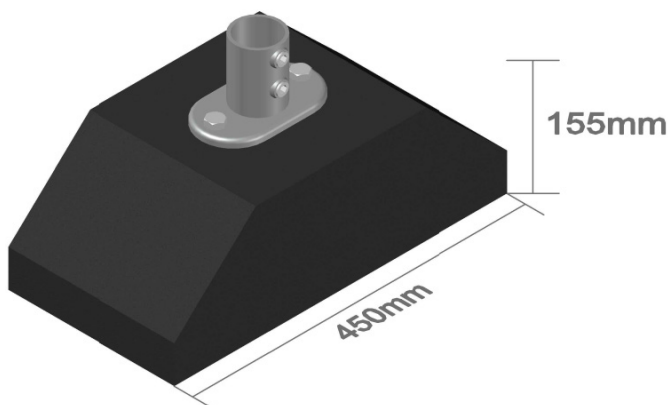

Intermediate Foot

The intermediate foot sits on the roof covering, positioned adjacent to the edge of the rooflight. A railing base flange is mechanically attached to this using zinc coated fixings, providing a base for upright stanchions.

Weighing 16 kg, this bolsters the system stability.

Materials

Manufactured from recycled PVC compound.

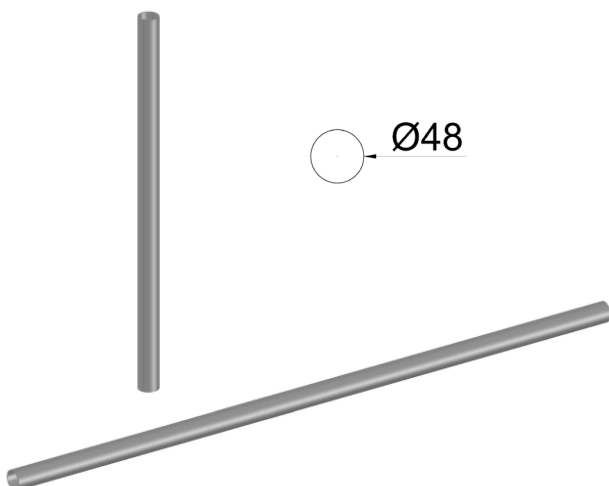

Upright & Cross Rail Tube

These components form the railing protection of the system

Materials

The lightweight main rail is manufactured from 1.5mm light gauge steel making it easy to cut and transport. It is galvanised coated to BS EN ISO 1461 and is also available powder coated to any RAL colour.

Components

Free Standing Roofligh Protection - System Components



3 Way 90 Degree Elbow (RC20)

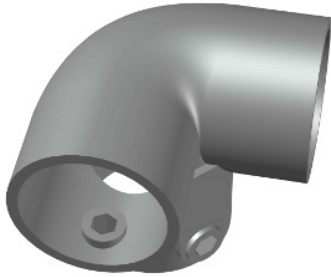

This fitting is used on the corner of the top rail. It provides quick and easy installation of the system using a simple hex key.

Materials

The fittings are manufactured from malleable cast iron and is galvanised coated equivalent to BS EN ISO 1461. These are also available powder coated to any RAL colour.

90 Deg Corner with Through Tube (RC21)



This fitting is used on the corner of the mid rail. It provides quick and easy installation of the system using a simple hex key.

Materials

The fittings are manufactured from malleable cast iron and is galvanised coated equivalent to BS EN ISO 1461. These are also available powder coated to any RAL colour.

Side Outlet Tee (RC23)

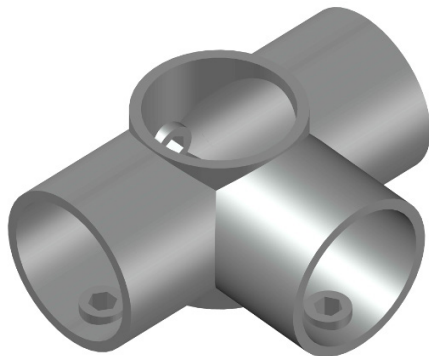

This fitting is used on the intermediate upright of both the top rail and mid rail. It provides quick and easy installation of the system using a simple hex key.

Materials

The fittings are manufactured from malleable cast iron and is galvanised coated equivalent to BS EN ISO 1461. These are also available powder coated to any RAL colour.

Configuration

Free Standing Rooflight Protection - System Configuration



Typical Layout & Dimensions

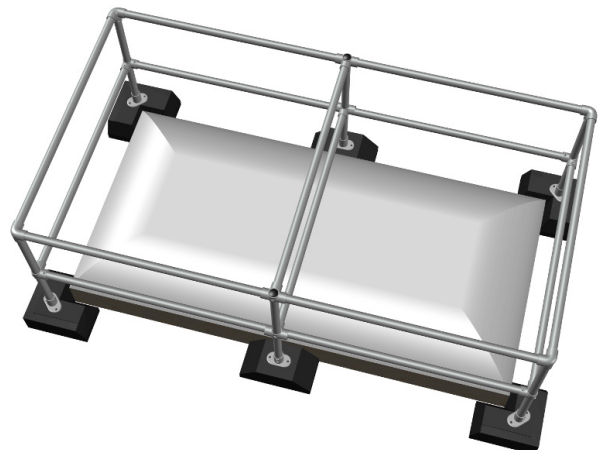
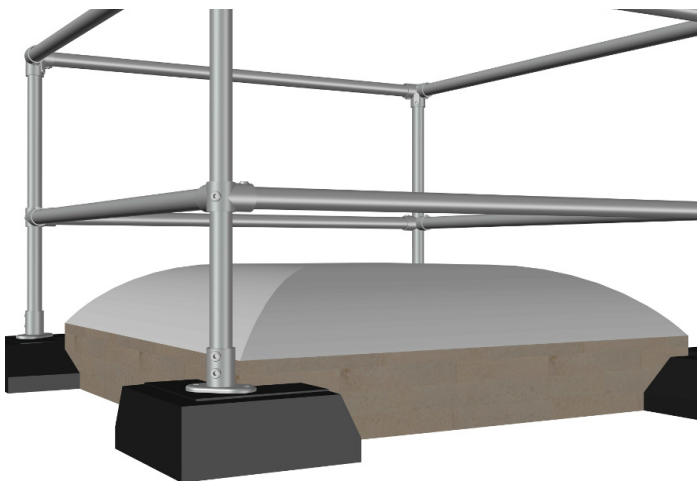
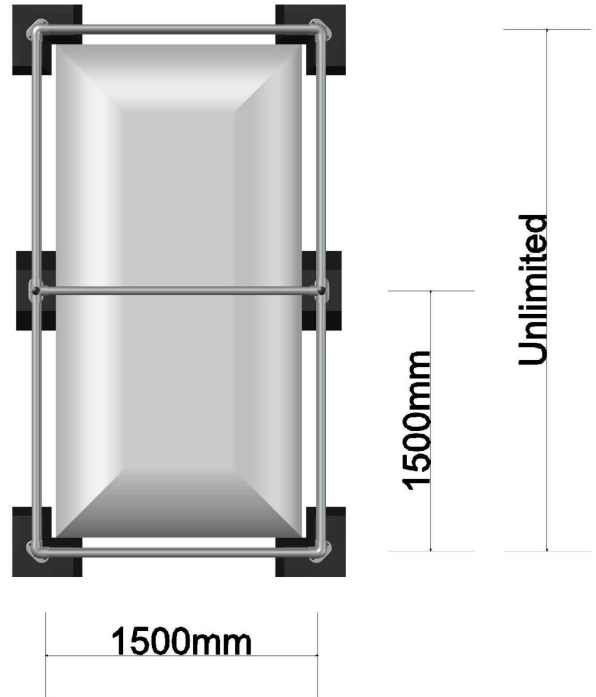
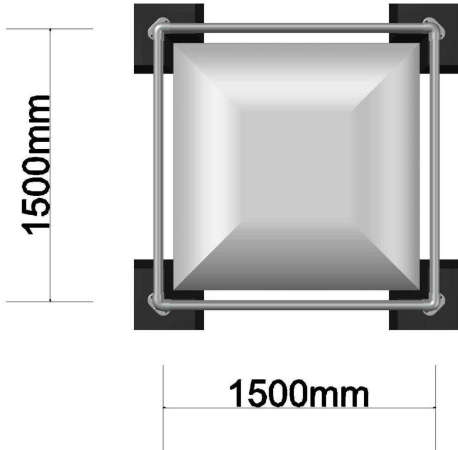
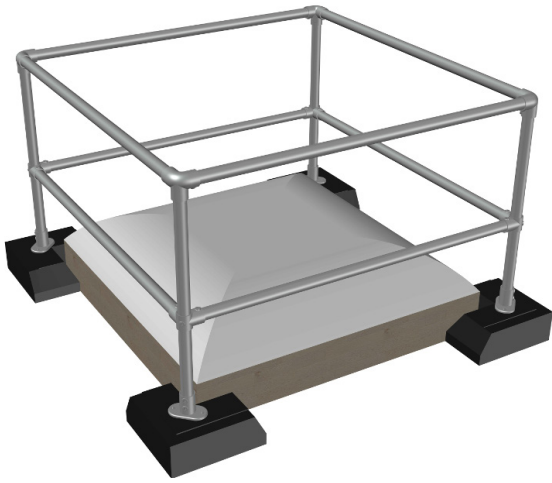

Installation

Free Standing Rooflight Protection - System Installation



- Prior to installation, ensure safe working distances from any fall hazards.
- Begin by fitting the upright tubes to the base feet.
- Then set the 3 Way 90 Degree Elbows, the 90 Deg Corners with Through Tube and the Side Outlet Tees at required heights on the upright tube.
- Install the cross rail tubes into the corners fittings.
- Position any intermediate feet and attach the cross rail tubes to the Side Outlet Tees.
- Tighten up all grub screws.

Maintenance

Free Standing Rooflight Protection - System Maintenance

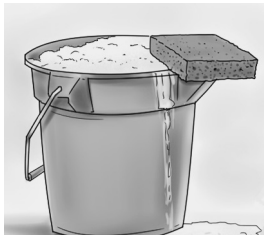

The system is maintenance free, however if cleaning is required, use only a mild detergent and water (such as a domestic washing up liquid) in order not to damage any of the galvanised coating.

Re-Certification

Free Standing Rooflight Protection - System Re-Certification

- We recommend that the installation should be inspected periodically by a competent person. The frequency of these inspections will depend upon the environment, location and utilisation, but should be at least every twelve months.
- Visual inspection of the complete installation in accordance with the current needs of the client.
- Check against the original installation drawing to see if any part of the installation has been modified.
- Check all screws and fixings are in place and sufficiently tightened.
- Check the height of the rails and that they are level.